

Jandy[®] Pro Series Water Feature Pump Model WFTR

⚠ WARNING

FOR YOUR SAFETY - This product must be installed and serviced by a contractor who is licensed and qualified in pool equipment by the jurisdiction in which the product will be installed where such state or local requirements exist. The maintainer must be a professional with sufficient experience in pool equipment installation and maintenance so that all of the instructions in this manual can be followed exactly. Before installing this product, read and follow all warning notices and instructions that accompany this product. Failure to follow warning notices and instructions may result in property damage, personal injury, or death.

Improper installation and/or operation will void the warranty.



Improper installation and/or operation can create unwanted electrical hazard which can cause serious injury, property damage, or death.

ATTENTION INSTALLER - This manual contains important information about the installation, operation and safe use of this product. This information should be given to the owner/operator of this equipment.

Table of Contents

<p>Section 1. Important Safety Instructions 4</p> <p>1.1 Safety Instructions..... 4</p> <p>1.2 Pool Pump Suction Entrapment Prevention Guidelines 6</p> <p>Section 2. General Description 7</p> <p>2.1 Introduction..... 7</p> <p>2.2 Description 7</p> <p>Section 3. Installation..... 8</p> <p>3.1 Plumbing 8</p> <p>3.2 Electrical Installation..... 9</p> <p>3.2.1 Voltage Checks 9</p> <p>3.3 Pressure Testing..... 10</p> <p>Section 4. Operation.....11</p> <p>4.1 Start-up.....11</p> <p>Section 5. Service and Maintenance.....11</p> <p>5.1 Routine Maintenance11</p> <p>5.2 Winterizing Pump 12</p>	<p>Section 6. Troubleshooting and Repair..... 13</p> <p>6.1 Troubleshooting..... 13</p> <p>6.2 Service Technician Maintenance..... 14</p> <p>6.2.5 Motor Replacement 17</p> <p>Section 7. Product Specifications and Technical Data 18</p> <p>7.1 Replacement Parts List 18</p> <p>7.2 Exploded View..... 19</p> <p>7.3 WFTR Pump Curves 20</p> <p>7.4 Physical and Operational Specifications 21</p> <p>7.5 Replacement Motor Guide 22</p>
---	---

EQUIPMENT INFORMATION RECORD

DATE OF INSTALLATION _____

INSTALLER INFORMATION _____

INITIAL PRESSURE GAUGE READING (WITH CLEAN FILTER) _____

PUMP MODEL _____ **HORSEPOWER** _____

NOTES: _____

Section 1. Important Safety Instructions

READ AND FOLLOW ALL INSTRUCTIONS

1.1 Safety Instructions

All electrical work must be performed by a licensed electrician and conform to all national, state, and local codes. When installing and using this electrical equipment, basic safety precautions should always be followed, including the following:

WARNING

RISK OF SUCTION ENTRAPMENT HAZARD, WHICH, IF NOT AVOIDED, CAN RESULT IN SERIOUS INJURY OR DEATH. Do not block pump suction as this can cause severe injury or death. Do not use this pump for wading pools, shallow pools or spas containing bottom drains, unless the pump is connected to at least two functioning suction outlets. Suction outlet (drain) covers must be certified to the latest published version of ANSI/ASME A112.19.8.

WARNING

To reduce the risk of injury, do not permit children to use this product.

WARNING

To reduce the risk of property damage or injury, do not attempt to change the backwash (multiport, slide, or full flow) valve position with the pump running.

WARNING

Jandy Pro Series pumps are powered by a high voltage electric motor and must be installed by a licensed or certified electrician or a qualified swimming pool service technician.

WARNING

Due to the potential risk of fire, electric shock, or injuries to persons, Jandy Pumps must be installed in accordance with the National Electrical Code (NEC), all local electrical and safety codes, and the Occupational Safety and Health Act (OSHA). Copies of the NEC may be ordered from the National Fire Protection Association, 470 Atlantic Ave., Boston, MA 02210, or received by contacting your local government inspection agency.

WARNING

Incorrectly installed equipment may fail, causing severe injury or property damage.

WARNING

- Do not connect the system to an unregulated city water system or other external source of pressurized water producing pressures greater than 35 PSI.
- Trapped air in system can cause the filter lid to be blown off, which can result in death, serious personal injury, or property damage. Be sure all air is out of the system before operating.

WARNING

To minimize the risk of severe injury or death the filter and/or pump should not be subjected to the piping system pressurization test.

Local codes may require the pool piping system to be subjected to a pressure test. These requirements are generally not intended to apply to the pool equipment such as filters or pumps.

Zodiac® pool equipment is pressure tested at the factory.

However, if the WARNING cannot be followed and pressure testing of the piping system must include the filter and/or pump, **BE SURE TO COMPLY WITH THE FOLLOWING SAFETY INSTRUCTIONS:**

- Check all clamps, bolts, lids, lock rings and system accessories to ensure they are properly installed and secured before testing.
- **RELEASE ALL AIR** in the system before testing.
- Water pressure for test must **NOT EXCEED 35 PSI**.
- Water temperature for test must **NOT EXCEED 100°F (38°C)**.
- Limit test to 24 hours. After test, visually check system to be sure it is ready for operation.

NOTICE: These parameters apply to Zodiac equipment only. For non-Zodiac equipment, consult equipment manufacturer.

WARNING

Chemical spills and fumes can weaken pool/spa equipment. Corrosion can cause filters and other equipment to fail, resulting in severe injury or property damage. Do not store pool chemicals near your equipment.

CAUTION

Do not start pump dry! Running the pump dry for any length of time will cause severe damage and will void the warranty.

CAUTION

This pump is for use with permanently installed pools and may also be used with hot tubs and spas if so marked. Do not use with storable pools. A permanently installed pool is constructed in or on the ground or in a building such that it cannot be readily disassembled for storage. A storable pool is constructed so that it may be readily disassembled for storage and reassembled to its original integrity.

CAUTION

Do not install within an outdoor enclosure or beneath the skirt of a hot tub or portable spa. The pump requires adequate ventilation to maintain air temperature at less than the maximum ambient temperature rating listed on the motor rating plate.

SAVE THESE INSTRUCTIONS

1.2 Pool Pump Suction Entrapment Prevention Guidelines

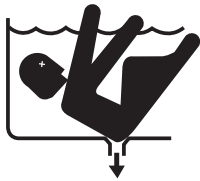

⚠ WARNING

SUCTION HAZARD. Can cause serious injury or death. Do not use this pump for wading pools, shallow pools or spas containing bottom drains, unless the pump is connected to at least two (2) functioning suction outlets.

⚠ WARNING

Pump suction is hazardous and can trap and drown or disembowel bathers. Do not use or operate swimming pools, spa, or hot tubs if a suction outlet cover is missing, broken, or loose. The following guidelines provide information for pump installation that minimizes the risk of injury to users of pools, spas, and hot tubs:

Entrapment Protection - The pump suction system must provide protection against the hazards of suction entrapment.

Suction Outlet Covers - All suction outlets must have correctly installed, screw-fastened covers in place. All suction outlet (drain) covers must be maintained. Drain covers must be listed/certified to the latest published version of ANSI/ASME A112.19.8. They must be replaced if cracked, broken, or missing.

Number of Suction Outlets Per Pump - Provide at least two (2) main drains, with covers, as suction outlets for each circulating pump suction line. The centers of the main drains (suction outlets) on any one (1) suction line must be at least 3 feet apart, center to center. See Figure 1 on page 7. For additional details and guidelines, refer to ANSI/APSP 7, the standard for *Suction Entrapment Avoidance in Swimming Pools, Wading Pools, Spas, Hot Tubs, and Catch Basins*.

The system **must** be built to include at least two (2) suction outlets (drains) connected to the pump whenever the pump is running. However, if two (2) main drains run into a single suction line, the single suction line may be equipped with a valve that will shut off both main drains from the pump. The system shall be constructed such that it shall not allow for separate or independent shutoff or isolation of each drain. See Figure 1 on page 7.

More than one (1) pump can be connected to a single suction line as long as the requirements above are met.

Water Velocity - The maximum water velocity through the suction fitting or cover for any suction outlet must be 1.5 feet per second, unless the outlet complies with the latest published version of ANSI/ASME A112.19.8, the standard for *Suction Fittings For Use in Swimming and Wading Pools, Spas, Hot Tubs, and Whirlpool Bathtub Applications*. In any case, do not exceed the suction fitting's maximum designed flow rate.

If 100% of the pump's flow comes from the main drain system, the maximum water velocity in the pump suction hydraulic system must be 6 feet per second, or less even if one (1) main drain (suction outlet) is completely blocked. The flow through the remaining main drain(s) must comply with the latest published version of ANSI/ASME A112.19.8, the standard for *Suction Fittings For Use in Swimming and Wading Pools, Spas, Hot Tubs, and Whirlpool Bathtub Applications*.

Testing and Certification - Suction outlet covers must have been tested by a nationally recognized testing laboratory and found to comply with the latest published version of ANSI/ASME A112.19.8, the standard for *Suction Fittings For Use in Swimming and Wading Pools, Spas, Hot Tubs, and Whirlpool Bathtub Applications*.

Fittings - Fittings restrict flow; for best efficiency use the fewest possible fittings (but at least two (2) suction outlets).

Avoid fittings that could cause an air trap.

Pool cleaner suction fittings must conform to applicable International Association of Plumbing and Mechanical Officials (IAPMO) standards.

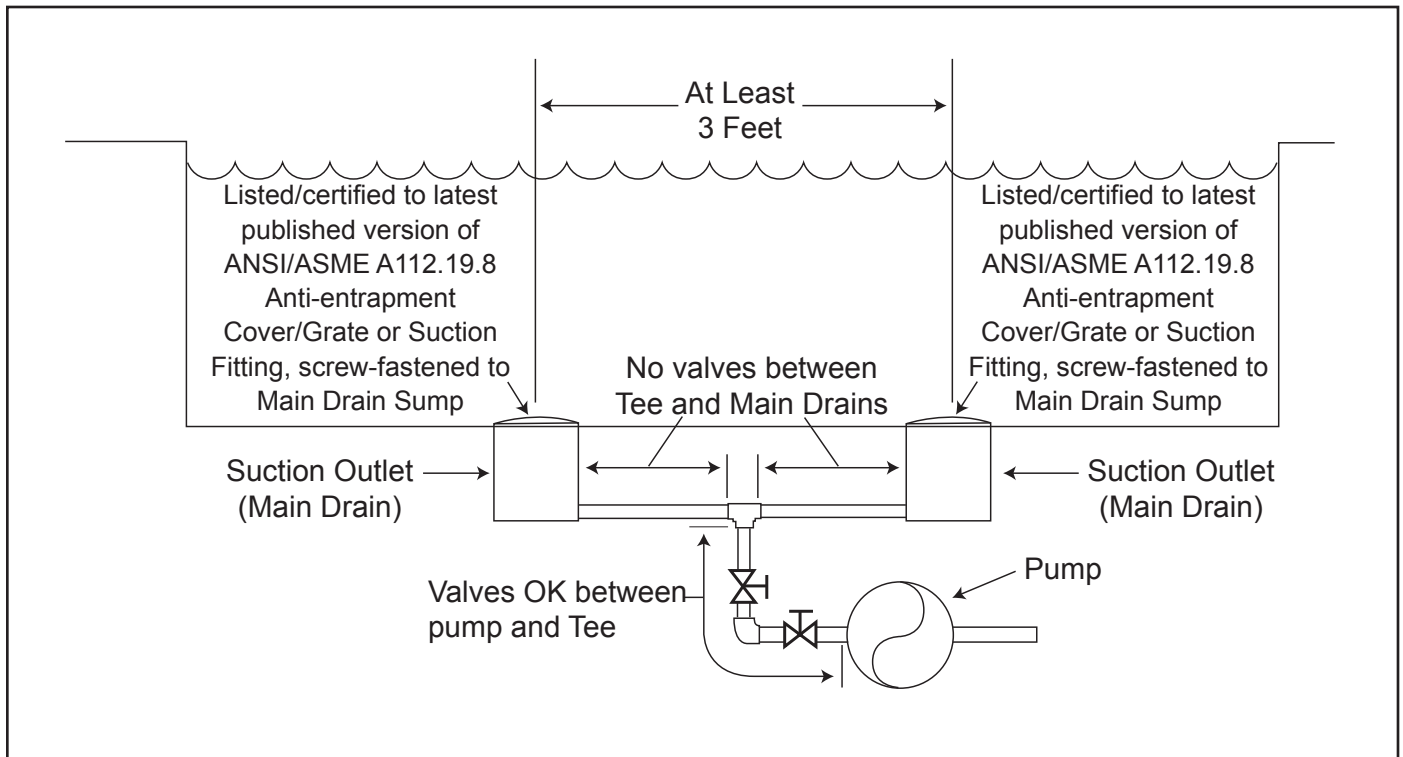

Figure 1. Number of Suction Outlets Per Pump

Section 2. General Description

2.1 Introduction

This manual contains information for the proper installation, operation and maintenance of Jandy Pro Series Water Features (WFTR) Pumps. Procedures in this manual must be followed exactly. To obtain additional copies of this manual contact Zodiac Pool Systems, Inc. at 800.822.7933. For address information, see the back cover of this manual.

2.2 Description

WFTR Pumps are designed to meet the needs of today's more hydraulically demanding pool equipment. The pump housing, backplate, diffuser, hair and lint pot (pump debris filter basket), and impeller are all made from high quality thermoplastic materials. These materials were chosen for their strength and corrosion resistance.

The pump is driven by an electric motor directly attached to the pump impeller. As the electric motor turns, it causes the impeller to turn, which forces water to flow through the pump. The water flows through the pump inlet and then into the filter basket. The basket assembly pre-strains/traps large particles. The water then enters the center of the pump housing, flows through the impeller into the diffuser, and then flows out the pump discharge port.

Section 3. Installation

3.1 Plumbing

3.1.1 Preparation

1. Upon receipt of the pump, check the carton for damage. Open the carton and check the pump for concealed damage, such as cracks, dents or a bent base. If you find damage, contact the shipper or the distributor where the pump was purchased.
2. Inspect the contents of the carton and verify that all parts are included. *See Section 7.1, Replacement Parts List.*

3.1.2 Pump Location

1. Zodiac Pool Systems, Inc. recommends installing the pump within 1 foot above water level. The pump should not be elevated more than a few feet above the water level of the pool. A check valve is recommended on the suction line to the pump.

NOTE Better self-priming will be achieved if the pump is installed as close as possible to the water level of the pool.

2. If the pump is located below water level, isolation valves must be installed on both the suction and return lines to prevent back flow of pool water during any routine or required servicing.

WARNING

Some Safety Vacuum Release System (SVRS) devices are not compatible with installation of check valves. If the pool has an SVRS device, be sure to confirm that that it will continue to safely operate when any check valves are installed.

3. Zodiac Pool Systems, Inc. recommends that the pump and other circulation equipment be located more than 5 feet from the water. Choose a location that will minimize turns in the piping.

NOTE In Canada, the pump must be located a minimum of 3 meters (approximately 10 feet) from the water (CSA C22.1).

4. The pump must be placed on a solid foundation that will not vibrate. To further reduce the possibility of vibration noise, bolt the pump to the foundation, or place it on a rubber mat.

NOTE Zodiac Pool Systems, Inc. recommends bolting the pump directly to the foundation.

5. The pump foundation must have adequate drainage to prevent the motor from getting wet. Protect the pump from the rain and sun.
6. Proper ventilation is required for the pump to operate normally. All motors generate heat that must be removed by providing proper ventilation.
7. Provide access for future service by leaving a clear area around the pump. Allow plenty of space above the pump to remove the lid and basket for cleaning.
8. If the equipment is under cover, provide adequate lighting.

3.1.3 Pipe Sizing

3.1.3.1 Suction Pipe

When the pump is located up to 50 feet from the pool, the recommended **Schedule 40** minimum pipe size for the suction side of the pump is 2" for 1 to 2 HP. For 2.5 HP pumps, the recommended pipe size is 2½".

3.1.3.2 Discharge Pipe

When the pump is located up to 50 feet from the pool, the recommended Schedule 40 minimum pipe size for the discharge side of the pump is 2" for 1 to 2 HP. For 2.5 HP pumps, the recommended pipe size is 2½".

NOTE All pipe sizes (Schedule 40) are able to withstand the pressures the pump will deliver, but not necessarily the flow. If the pipe is too small for the pump, or if the pump is elevated above water, the maximum gallons per minute (GPM) may not be delivered. If this happens, the pump will develop an air pocket (cavitation) that will make noise, and the life of the pump might be shortened.

3.1.3.3 Installation Recommendations

1. If the pump is located below water level, isolation valves *must* be installed on both sides of the pump to prevent back flow of pool water during any routine or required servicing.
2. To help prevent difficulty in priming, install the suction pipe without high points (above inlet of pump - inverted "U"s in plumbing commonly referred to as an airlock), which can trap air. For installations of equipment up to 100 feet from the water, refer to the pipe sizing chart in Table 1. For installations of equipment more than 100 feet from the water, the recommended pipe size must be increased to the next size.

Table 1. Pipe Sizing Chart for Schedule 40 PVC

Pipe Size	Maximum Flow Suction (8 feet per second)	Maximum Flow Discharge (10 feet per second)
2"	85 GPM (322 LPM)	105 GPM (397 LPM)
2½"	120 GPM (454 LPM)	149 GPM (564 LPM)
3"	184 GPM (697 LPM)	230 GPM (871 LPM)

- WFTR Pumps come equipped with unions on both the suction and discharge ports. This feature simplifies installation and service, and it eliminates the possibility of leaks at threaded adapters.
- The WFTR Pump must be connected to at least two (2) main drains (suction outlets) for each pool pump suction line. Each drain must be provided with covers that are listed or certified to the latest published version of ANSI/ASME A112.19.8. The suction outlets of the main drains must be at least 3 feet apart or at different planes. The suction outlets can be a drain and skimmer, two (2) drains, two (2) skimmers, or a skimmer with an equalizer line installed. For additional details and guidelines, refer to ANSI/APSP 7, the standard for *Suction Entrapment Avoidance in Swimming Pools, Wading Pools, Spas, Hot Tubs, and Catch Basins*. Check the local codes for proper installation requirements. Applicable local codes will take precedence over other codes.

NOTE To prevent entrapment, the system must be built so that it cannot operate with the pump drawing water from only one (1) main drain. At least two (2) main drains **must** be connected to the pump when it is in operation. However, if two (2) main drains run into a single suction line, the single suction line may be equipped with a valve that will shut off both main drains from the pump.

- The piping must be well supported and not forced together in places where constant stress will be experienced.
- Always use properly sized valves. Jandy Pro Series Diverter Valves and Ball Valves typically have the best flow capabilities.
- Use the fewest fittings possible. Every additional fitting has the effect of moving the equipment farther away from the water.

NOTE If more than 10 suction fittings are needed, the pipe size must be increased.

- Every new installation must be pressure tested according to local codes. See *Section 3.3, Pressure Testing*.

3.2 Electrical Installation

3.2.1 Voltage Checks

The correct voltage, as specified on the pump data plate, is necessary for proper performance and long motor life. The incorrect voltage will decrease the pump's ability to perform and could cause overheating, reduce the motor life, and result in higher electric bills.

It is the responsibility of the electrical installer to provide data plate operating voltage to the pump by ensuring proper circuit sizes and wire sizes for this specific application.

CAUTION

Failure to provide data plate voltage (within 10%) during operation will cause the motor to overheat and will void the warranty.

3.2.2 Bonding and Grounding

- The motor frame must be grounded to a reliable grounding point using a solid copper conductor, No. 8 AWG or larger. In Canada, No. 6 AWG or larger must be used. If the pump is installed within 5 feet of the inside walls of the swimming pool, spa, or hot tub, the motor frame must be bonded to all metal parts of the swimming pool, spa, or hot tub structure and to all electrical equipment, metal conduit, and metal piping within 5 feet of the inside walls of the swimming pool, spa, or hot tub.
- Bond the motor using the provided external lug.

⚠ WARNING

To avoid risk of property damage, severe personal injury, and/or death, always disconnect the power source before working on a motor or its connected load.

⚠ WARNING

In order to avoid the risk of property damage, severe personal injury, and/or death, make sure that the control switch or time clock is installed in an easily accessible location, so that in the event of an equipment failure or a loose plumbing fitting, the equipment can be easily turned off.

CAUTION

The pump must be permanently connected to a dedicated electrical circuit. No other equipment, lights, appliances or outlets may be connected to the pump circuit, with the exception of devices that may be required to operate simultaneously with the pump, such as a chlorinating device or heater. to both the pump and motor and will void the warranty.

3.2.3 Electrical Wiring

⚠ WARNING

To avoid risk of property damage, severe personal injury, or death, always ground before connecting to an electrical power supply.

1. The pump motor must be securely and adequately grounded using the green screw provided. Ground before attempting to connect to an electrical power supply. **Do not ground to a gas supply line.**
2. Wire size must be adequate to minimize a voltage drop during the start-up and operation of the pump. See Table 2 for suggested wire sizes.
3. Insulate all connections carefully to prevent grounding or short-circuits. Provide extra protection for sharp edges on terminals. To prevent wire nuts from loosening, tape them with a suitable, listed (UL, ETL, CSA) electrical insulating tape. For safety, and to prevent entry of contaminants, reinstall all conduit and terminal box covers. **Do not force connections into the conduit box.**
4. To configure the pump motor's internal wiring for the correct voltage, refer to the diagram on the motor data plate.

3.3 Pressure Testing

⚠ WARNING

When pressure testing a system with water, air is often trapped in the system during the filling process. This air will compress when the system is pressurized. Should the system fail, this trapped air can propel debris at a high speed and cause property damage, severe personal injury or death. Every effort to remove trapped air must be taken, including opening the bleed valve on the filter and loosening the pump basket lid while filling the pump.

⚠ WARNING

Trapped air in system can cause the filter lid to be blown off, which can result in death, serious injury, or property damage. Be sure all air is properly out of system before operating. **DO NOT USE COMPRESSED AIR TO PRESSURE TEST OR CHECK FOR LEAKS.**

⚠ WARNING

Do not pressure test above 35 PSI. Pressure testing must be done by a trained pool professional. Circulation equipment that is not tested properly may fail, which could result in severe injury or property damage.

⚠ WARNING

When pressure testing the system with water, it is very important to make sure that the pump basket lid is completely secure.

1. Fill the system with water, using care to eliminate trapped air.
2. Pressurize the system with water to no more than 35 PSI.
3. Close the valve to trap pressurized water in the system.
4. Carefully observe the system for leaks and/or pressure decay.

Table 2. Recommended Minimum Wire Size for WFTR Pumps

RECOMMENDED MINIMUM WIRE SIZE (AWG) FOR WFTR PUMPS*										
Distance from Sub-Panel			0-50 FEET		50-100 FEET		100-150 FEET		150 FEET-200 FEET	
Model	Branch Fuse AMPS Class: CC, G, H, J, K, RK, or T		Voltage		Voltage		Voltage		Voltage	
	230 VAC	115 VAC	230 VAC	115 VAC	230 VAC	115 VAC	230 VAC	115 VAC	230 VAC	115 VAC
WFTR 80	15A	20A	14	10	10	8	8	6	8	4
WFTR 120	15A	20A	12	10	10	6	8	6	6	4
WFTR 160	15A	NA	12	NA	8	NA	6	NA	6	NA

*Assumes three (3) copper conductors in a buried conduit and 3% maximum voltage loss in branch circuit. All National Electrical Code (NEC) and local codes must be followed. Table shows minimum wire size and branch fuse recommendations for typical installation per NEC.

Section 4. Operation

4.1 Start-up

CAUTION

Never run the pump without water. Running the pump "dry" for any length of time can cause severe damage to both the pump and motor and will void the warranty

If this is a new pool installation, make sure all piping is clear of construction debris and has been properly pressure tested. If a filter is installed in the system, it should be checked for proper installation, verifying that all connections and clamps are secure according to the manufacturer's recommendations.

⚠ WARNING

To avoid risk of damage or injury, verify that all power is turned off before starting this procedure.

1. If a filter is installed in the system, release all pressure from the system and open the filter pressure release valve.
2. If the pump is located below the water level of the pool, opening the lid should allow water to fill the basket area. If a filter is installed in the system, opening the filter pressure release valve will prime the pump with water.
3. If the pump is located above the water level of the pool, remove the lid and fill the basket with water before starting the pump.
4. To prevent air from leaking into the system, remove any debris around the lid seal seat.
5. Hand-tighten the lid to make an air tight seal. **Do not use any tools: hand-tighten only.** Ensure that the lid is secure. Make sure all valves are open and the unions are tight.
6. Restore power to the pump, then turn on the pump.
7. If a filter is installed in the system, when all the air has left the filter, close the filter pressure release valve.
8. The pump should prime. The time it takes to prime will depend on the elevation and length of pipe used on the suction supply pipe. See *Section 3.1.3.3, Installation Recommendations* for proper elevation and pipe size.

9. If the pump does not prime and all the instructions to this point have been followed, check for a suction leak and then repeat Steps 2 through 7.
10. For technical assistance, contact Technical Support Department at (800) 822-7933.

Section 5. Service and Maintenance

5.1 Routine Maintenance

Inspect the pump basket for debris by looking through the clear pump lid. Remove any debris, because as debris accumulates, it will begin to block the flow of water through the pump. Keep the basket clean to improve the performance of the pump.

1. Turn off the power to the pump. If the pump is located below water level, close the isolation valves on the suction and discharge sides of the pump to prevent backflow of water.
2. Turn the lid's locking ring counter-clockwise until the 'START' marking aligns with the ports. Carefully remove the locking ring and the lid.

CAUTION

A misaligned basket will cause the lid to be improperly seated, allowing an air leak, which could result in pump damage.

3. Lift the basket out of the pump. Dispose of all debris and thoroughly clean the basket, making sure all the holes are open. Using a garden hose, spray the basket from the outside to help clear the holes. Remove any remaining debris by hand.
4. Replace the basket in the pump by aligning the open section of the basket with the inlet pipe. If aligned properly, the basket will drop easily into place. **Do not force it into place.**
5. Remove the lid seal and remove debris around the lid groove, as this will cause air leaks in the system. Clean the lid groove and the lid seal.
6. Note that one (1) side of the lid seal has two (2) ribs and the other has one (1). Place the side with two (2) ribs into the groove. See Figure 2.

- Replace the lid with locking ring on the pump housing. Align 'START' with the ports and turn the lid's locking ring clockwise until 'LOCKED' aligns with the ports. **Hand-tighten** the lid to make an air tight seal. **Do not use any tools to tighten the lid.**

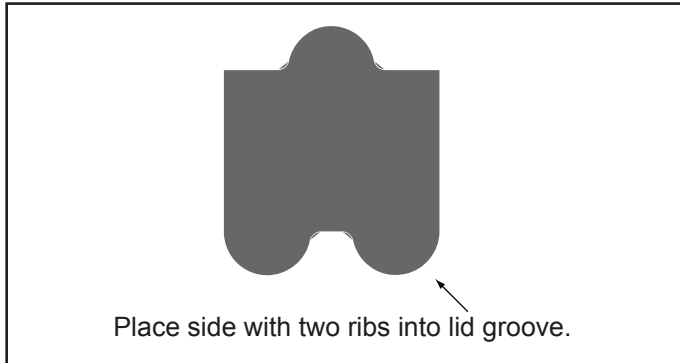

Figure 2. Cross Section of Lid Seal

- Verify that all valves have been returned to the proper position for normal operation.
- If a filter is installed in the system, open the pressure release valve on the filter, and make sure it is clean and ready for operation.
- Turn on the power to the pump. If a filter is installed in the system, when all the air has been evacuated from the filter, close the filter pressure release valve.

NOTE Zodiac Pool Systems, Inc. recommends having a qualified service technician or electrician properly disconnect the electrical wiring at the switch or junction box. Once the power is removed, loosen the two (2) unions and store the pump indoors. For safety, and to prevent entry of contaminants, reinstall all conduit and terminal box covers.

- When the system is reopened for operation, have a qualified service technician or electrician make sure all piping, valves, wiring, and equipment are in accordance with the manufacturer's recommendations. Pay close attention to any filter and electrical connections.
- The pump must be primed prior to starting; refer to *Section 4.1, Start-up*.

5.2 Winterizing Pump

CAUTION

The pump must be protected when freezing temperatures are expected. Allowing the pump to freeze will cause severe damage and void the warranty.

CAUTION

Do not use antifreeze solutions in the pool, spa, or hot tub systems! Antifreeze is highly toxic and may damage the circulation system. The only exception to this is Propylene Glycol. For more information, see your local pool/spa supply store or contact a qualified swimming pool service company.

- Drain **all** water from the pump, system equipment, and piping.
- Remove the two (2) drain plugs and store them in a safe place. Reinstall them when the cold weather season is over. **Do not lose the o-rings.**
- Keep the motor covered and dry. Do not cover the pump with plastic. This creates condensation that will damage the pump.

Section 6. Troubleshooting and Repair

Zodiac Pool Systems, Inc. strongly recommends that you call a qualified service technician to perform any repairs on the pump system. To locate a qualified technician, check your local yellow pages or visit www.jandy.com and click on “Product Support.”

6.1 Troubleshooting

Symptom	Possible Problem/Solution
The cleaning/circulating system is not operating correctly.	<p>Verify that skimmer baskets, pump basket and other screens are clean. Clean as necessary.</p> <p>If a filter is installed in the system, check the filter and clean as necessary.</p> <p>Check valve positions. Adjust as necessary.</p> <p>NOTE Multiple pieces of equipment operating at one time (for example, waterfalls, spa jets, and surface returns) may affect the cleaning system and prevent it from working properly.</p> <p>Check cleaning system manual to ensure the system is adjusted according to manufacturer's recommendations.</p>
Bubbles present in the pump basket.	<p>Air is in system. Check pool or spa water level to ensure it is at the proper level and air is not being drawn into suction piping. If water is at normal level, turn off pump. Turn the lid's locking ring counter-clockwise until 'START' aligns with ports. Remove lid and check for debris around lid seal seat or improper installation of lid seal, as either of these conditions will cause air leaks in the system. Clean lid seal and lid groove. Note that one (1) side of lid seal has two (2) ribs and the other has one (1). See Figure 2. Place the side with two (2) ribs into lid groove. Replace lid on pump housing. Align 'START' with ports and turn lid's locking ring clockwise until 'LOCKED' aligns with ports. Hand-tighten the lid to make an air tight seal. Do not use any tools to tighten the lid. Turn the pump back on.</p>
Air leaks are still present.	<p>Check the suction side piping union. While the pump is running, try to tighten the union. If this does not stop the air leak, turn off the pump. Loosen both unions and slide the pump out of the way. Remove, clean, and re-install both union o-rings.</p> <p>Reposition the pump next to the piping and secure the union nuts to the pump. With clean union o-rings, hand-tightening of the unions should create a seal. If the unions still do not seal, gently tighten with a large pair of tongue-and-groove pliers.</p> <p>Do not over-tighten.</p>
There is no air in the system, but the pressure is still low.	<p>It is possible that debris is caught in the pump impeller. The pump impeller moves the water, and the vanes in the impeller can become blocked with debris. See <i>Section 6.2, Service Technician Maintenance, 6.2.1, Blocked Impeller</i>, for more information.</p>
There is no debris blocking the impeller and the pressure is still low.	<p>The pump impeller and diffuser are showing signs of normal wear. Have a qualified service technician check the impeller and diffuser and replace as necessary.</p> <p>If the pump is part of a relatively new installation, it could be an electrical problem. Contact a qualified service technician. Have the technician check for loose electrical connections and check the voltage at the pump motor while it is in operation. The voltage must be within 10% of the motor's data plate rating. If the voltage is not within 10%, contact a qualified electrician and/or the local power service provider.</p> <p>The pump seal is leaking air. Have a qualified service technician replace the seal.</p>
The pump is leaking water between the motor and pump body.	<p>This is caused by a damaged or failed mechanical seal. Replace the seal. See <i>Section 6.2, Service Technician Maintenance, 6.2.4, Mechanical Seal Replacement</i>.</p>
The pump gets hot and shuts off periodically.	<p>Ensure that there is adequate room around the motor to circulate air and keep motor cool. Have a qualified electrician check for loose connections and check voltage at the pump motor while it is in operation. The voltage must be within 10% of the motor's data plate rating. If voltage is not within 10%, contact a qualified electrician and/or the local power service provider.</p>

6.2 Service Technician Maintenance

⚠ WARNING

This pump must be serviced by a professional service technician, qualified in pool/spa installation. The following procedures must be followed exactly. Improper installation and/or operation can create dangerous electrical hazards, which can cause high voltages to run through the electrical system, possibly causing property damage, serious injury, or death. Improper installation and/or operation will void the warranty.

6.2.1 Blocked Impeller

⚠ WARNING

While servicing the pump, switch off the circuit breakers at the power source. Severe personal injury or death may occur if the pump starts while your hand is inside the pump.

1. Turn off the pump. Switch off the circuit breaker to the pump motor.
2. Remove the lid and basket.
3. Look inside the pump for debris. Remove any debris found inside.
4. Replace the basket and lid.
5. Switch on the circuit breaker to the pump motor.
6. Turn on the pump, and see if the problem is solved.
7. If the impeller is still blocked with debris and it is not possible to remove the debris using Steps 2 through 4, the pump will need to be disassembled in order to access the inlet and outlet of the impeller.

6.2.2 Impeller Removal

⚠ WARNING

While servicing the pump, switch off the circuit breakers at the power source. Severe personal injury or death may occur if the pump starts while your hand is inside the pump.

1. Turn off the pump. Switch off the circuit breaker to the pump motor. If you are not replacing the motor, do not disconnect the electrical wiring.

NOTE If you are replacing the motor, Zodiac Pool Systems, Inc. strongly recommends that a qualified service technician or electrician properly disconnect the electrical wiring at the pump motor.

2. Turn off any valves to prevent pool water from reaching the pump. Drain the water from the pump by loosening the unions or removing the drain plugs.
3. Using a 9/16" wrench, loosen the bolts connecting the pump body to the motor backplate. See Figure 3.

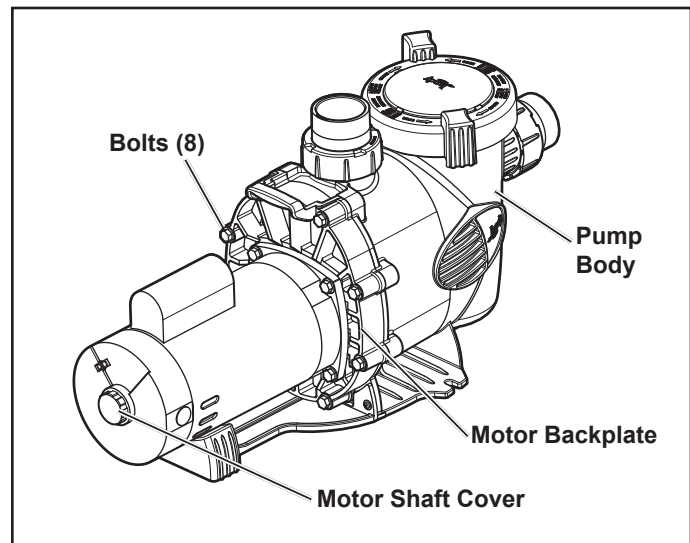

Figure 3. Remove the Pump Housing

4. Pull the motor and backplate out of the pump body. Remove the pump body o-ring. The impeller is connected to the motor shaft.
5. Using a No. 1 Phillips screwdriver, remove the two (2) screws holding the diffuser. (The diffuser is the cover over the impeller). Then remove the diffuser. See Figure 4.
6. Remove any debris from the inlet and outlet of the impeller.

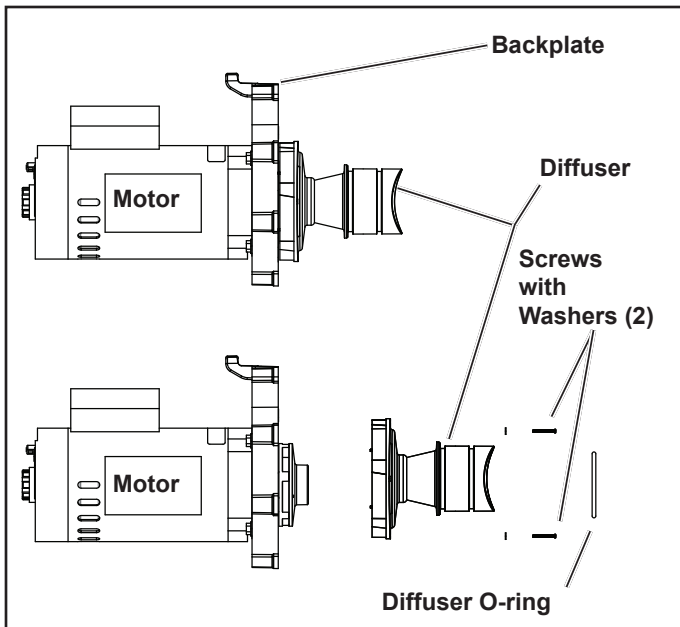

Figure 4. Remove the Diffuser

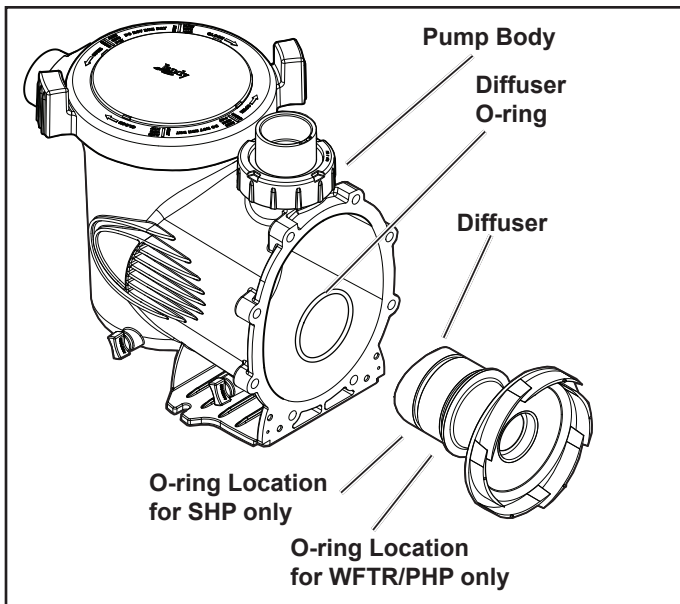

Figure 5. Location of Diffuser O-ring

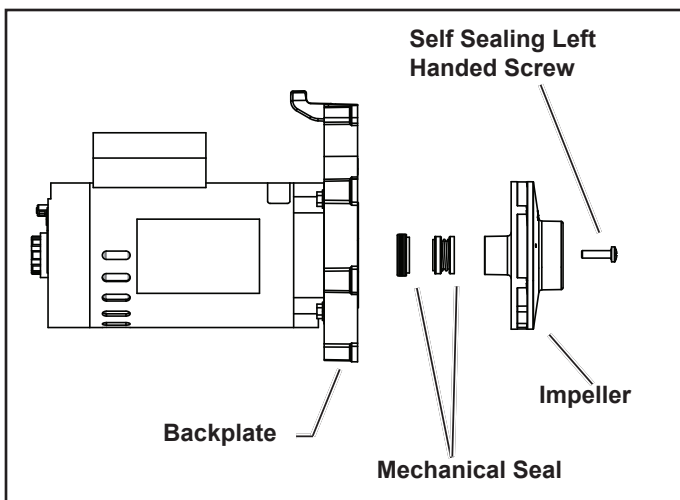

Figure 6. Remove the Impeller

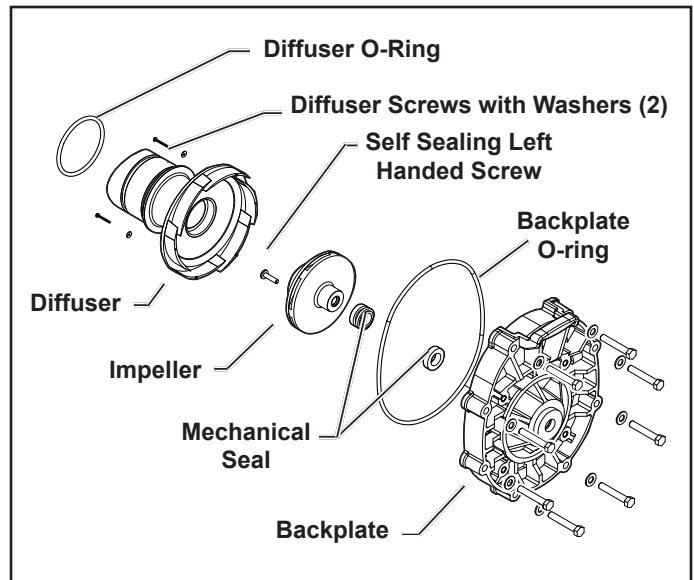

Figure 7. Diffuser and Impeller Exploded View

7. Remove the motor shaft cover on the back of the motor by twisting the hex-head screw with a 90° crescent wrench, see Figure 3. The motor shaft will be exposed.
8. Hold the exposed motor shaft with a ½" wrench while removing the impeller center screw using a No. 2 Phillips screwdriver. Since the impeller center screw is a left-hand threaded screw, turn it clockwise to loosen it. See Figure 6.
9. Hold the motor shaft with a ½" wrench while unscrewing the impeller from the motor shaft with your hand. Since the impeller is a right-hand thread, turn the impeller counter-clockwise to unscrew it.
10. Inspect the impeller and diffuser for signs of rubbing and/or damage.

6.2.3 Impeller Replacement

1. Press the carbon face seal half, see Figure 8, on the motor shaft using a twisting motion. Make sure the carbon surface is facing toward the ceramic ring in the backplate.

CAUTION

VERY IMPORTANT! Grasp the lower portion of the seal (opposite the carbon face) when installing the seal or it will be damaged.

NOTE To assist assembly, only use water or a soap solution as a lubricant. Any other lubricant will destroy the seal after a short period of time.

NOTE Take great care to keep the seal and mating parts clean.

2. While holding the motor shaft with a 1/2" wrench, thread the impeller onto the motor shaft. Hand-tighten the impeller until it is secure.
3. Install the impeller center screw into the center of the impeller and tighten, using a No. 2 Phillips screwdriver. Since the impeller center screw is left-hand threaded, turn the screw counter-clockwise to tighten it. **Do not overtighten.**
4. Replace the motor shaft cover by inserting the cover tabs into the slots and rotating the cover 90° clockwise.
5. Replace the diffuser over the impeller, using care to insert alignment pins into the correct holes. The molded-in arrow must point toward the handle of the backplate.
6. Replace the two (2) small Phillips-head screws. Tighten the screws to draw the diffuser against the motor backplate.

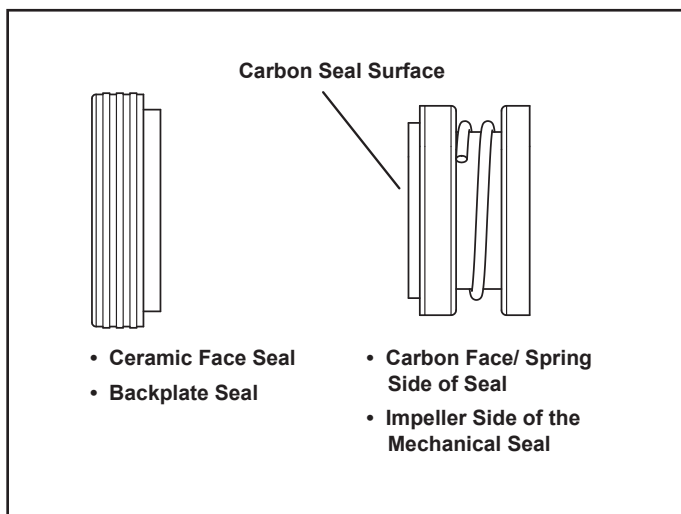

Figure 8. Replace the Mechanical Seal

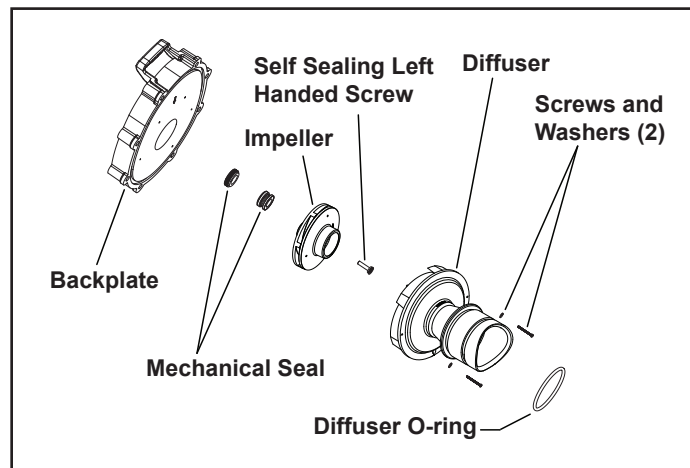

Figure 9. Backplate, Impeller, Diffuser, and Mechanical Seal Exploded View

7. Make sure the diffuser o-ring, o-ring groove, and o-ring seal area are clean and free of debris, which could cause a leak. If you removed the diffuser o-ring, make sure you install it into the proper groove, see Figure 5. If grease is used to retain the o-ring, it **must** be silicone based. **Do not** use petroleum-based grease. It **will** destroy the o-ring.
8. Slide the diffuser into the mating hole in the pump body. While supporting the motor, start two (2) screws on opposite sides. This will hold the motor in position while you start the other six (6) screws.
9. Tighten the screws lightly in a crossing "X" pattern using a 9/16" wrench starting with the inner (middle) four (4), then the outer (top and bottom) four (4) to draw the backplate to the body in an even manner. Once all the screws are snug, torque in the same order to 18 foot-pounds.
10. If the pump is located above water level of the pool, remove the lid and fill the basket with water before starting the pump.
11. To prevent air from leaking into the system, remove debris around the lid seal seat.
12. **Hand-tighten** the lid to make an air tight seal. **Do not use any tools to tighten the lid.**
13. If a filter is installed in the system, open the pressure release valve on the filter, and make sure it is clean and ready for operation.
14. Switch on the circuit breaker to the pump motor.
15. Turn on the pump and check the system for normal operation.
16. If a filter is installed in the system, when all the air has left the filter, close the filter pressure release valve.

6.2.4 Mechanical Seal Replacement

NOTE This is a two-part replacement process. *The mechanical seal must be replaced as a set.*

NOTE Refer to Figure 9 for the location of the mechanical seal and impeller.

⚠ WARNING

Do not damage the ceramic or carbon surfaces of the seals. If surfaces are damaged, leaks will occur.

1. To access the mechanical seal, comply with the warning and follow steps 1 through 8 of *Section 6.2.2, Impeller Removal*.
2. Remove the carbon face seal half from the motor shaft, see Figure 8. This is a spring-loaded seal. Grasp the portion of the seal closest to the impeller body and pull the seal off using a twisting motion.
3. Remove the motor from the backplate by complying with the caution and following steps 1 through 3 in *Section 6.2.5*.
4. Place the backplate o-ring side down and force the ceramic seal out using a screwdriver or drift.
5. Turn the backplate o-ring side up and insert the new ceramic seal side into the backplate. Use great care to press the seal in squarely with your fingers. The ceramic is easily damaged and must be pressed in using only your fingers or soft tools. Do not use any lubricant other than water and soap solution.
6. Install the motor by complying with the caution and following the steps in *Section 6.2.5, Motor Replacement*.
7. Install the backplate by complying with the caution and following the steps in *Section 6.2.3, Impeller Replacement*.

6.2.5 Motor Replacement

CAUTION

To ensure continued safety and reliable operation, Zodiac Pool Systems, Inc. requires that you replace the motor with a motor that has the identical HP rating and service factor (Zodiac Pool Systems, Inc. approved only).

1. Have a qualified service technician or electrician properly disconnect the electrical wiring at the pump motor.

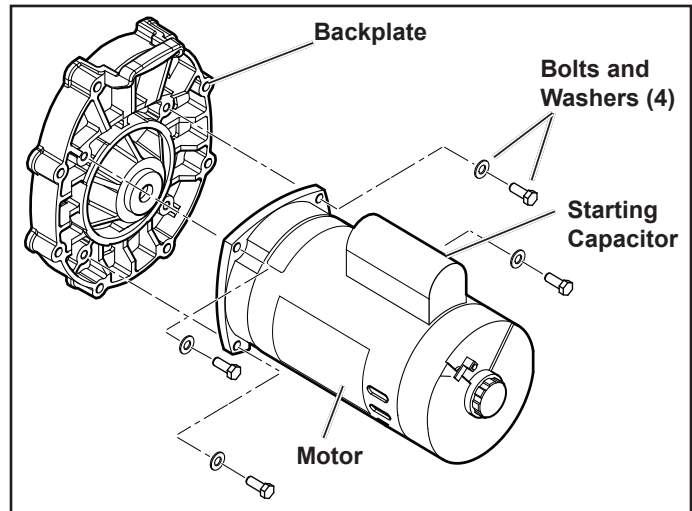

Figure 10. Backplate Assembly

2. To disassemble the pump housing from the motor, comply with the warning and follow steps 1 through 8 in *Section 6.2.2, Impeller Removal*.
3. Place the backplate motor assembly o-ring side down and unscrew the four (4) 9/16" screws and remove the motor.

NOTE Before removing the backplate, note the alignment of the backplate to the motor. See Figure 10.

4. If installing a new motor, remove the protective plastic cap from the motor shaft. Place the motor on the backplate so that the opening in the motor faces the bottom of the backplate. The starting capacitor on the motor should be at the 12 o'clock position.
5. Replace the four (4) bolts and washers holding the backplate to the motor.
6. To reassemble the pump after replacing the motor, comply with the caution and follow steps 1 through 13 of *Section 6.2.3, Impeller Replacement*.
7. Have a qualified service technician or electrician properly connect the electrical wiring at the pump motor.

NOTE Zodiac Pool Systems, Inc. recommends replacing the mechanical seal at the same time that you replace the motor. See *Section 6.2.4, Mechanical Seal Replacement*, for details.

Section 7. Product Specifications and Technical Data

7.1 Replacement Parts List

To order or purchase parts for Jandy Pro Series pumps, contact your nearest Zodiac® dealer. If they cannot supply you with what you need, contact Zodiac Technical Support at 800.822.7933 or send an e-mail message to techsupport.vista@zmp-zodiac.com.

Key No.	Description	Model No. (HP)	Order Part No.
1	Single-speed Motor and Hardware, WFTR80	1.0	R0479311
1	Single-speed Motor and Hardware, WFTR120	1.5	R0479312
1	Single-speed Motor and Hardware, WFTR160	2.5	R0479314
1	Bolts and Washers (Set of 4)	All	R0479310-14
2	Backplate Kit w/Hardware, O-ring & Mech Seals, WFTR	All	R0445200
3	Impeller & Diffuser w/Screw and O-ring, WFTR	1.0	R0449502
3	Impeller & Diffuser w/Screw and O-ring, WFTR	1.5	R0449503
3	Impeller & Diffuser w/Screw and O-ring, WFTR	2.5	R0449505
3	Screw w/O-ring, Self-sealing	All	R0449501-05
4	Diffuser w/O-ring & Hardware	All	R0445400
5	Mechanical Seal (Carbon and Ceramic)	All	R0479400
6	Body, Pump, WFTR	All	R0448701
7	Motor Mounting Foot Assembly w/ 2 Screws, WFTR	All	R0445700
8	Locking Ring w/ Lid and Seal	All	R0448800
9	Pump DebrisFilter Basket	All	R0448900
10	Drain Plug w/ O-ring	All	R0446000
11	Tail Piece (2" by 2½") w/O-ring and Coupling Nut (Set of 2)	All	R0449000
12	Lid Seal and Lid O-ring (Lid O-ring Not Shown)	All	R0449100
13	O-ring, Backplate	All	R0446300
14	O-ring, Tail Piece	All	R0449200
15	Diffuser/Impeller w/ O-rings & Mounting Hardware	All	R0446500
16	Backplate Bolts and Washers	All	R0446600
17	Motor Bolts & Washers	All	R0446700
18	Screws, Motor Mounting Foot	All	R0446800

7.2 Exploded View

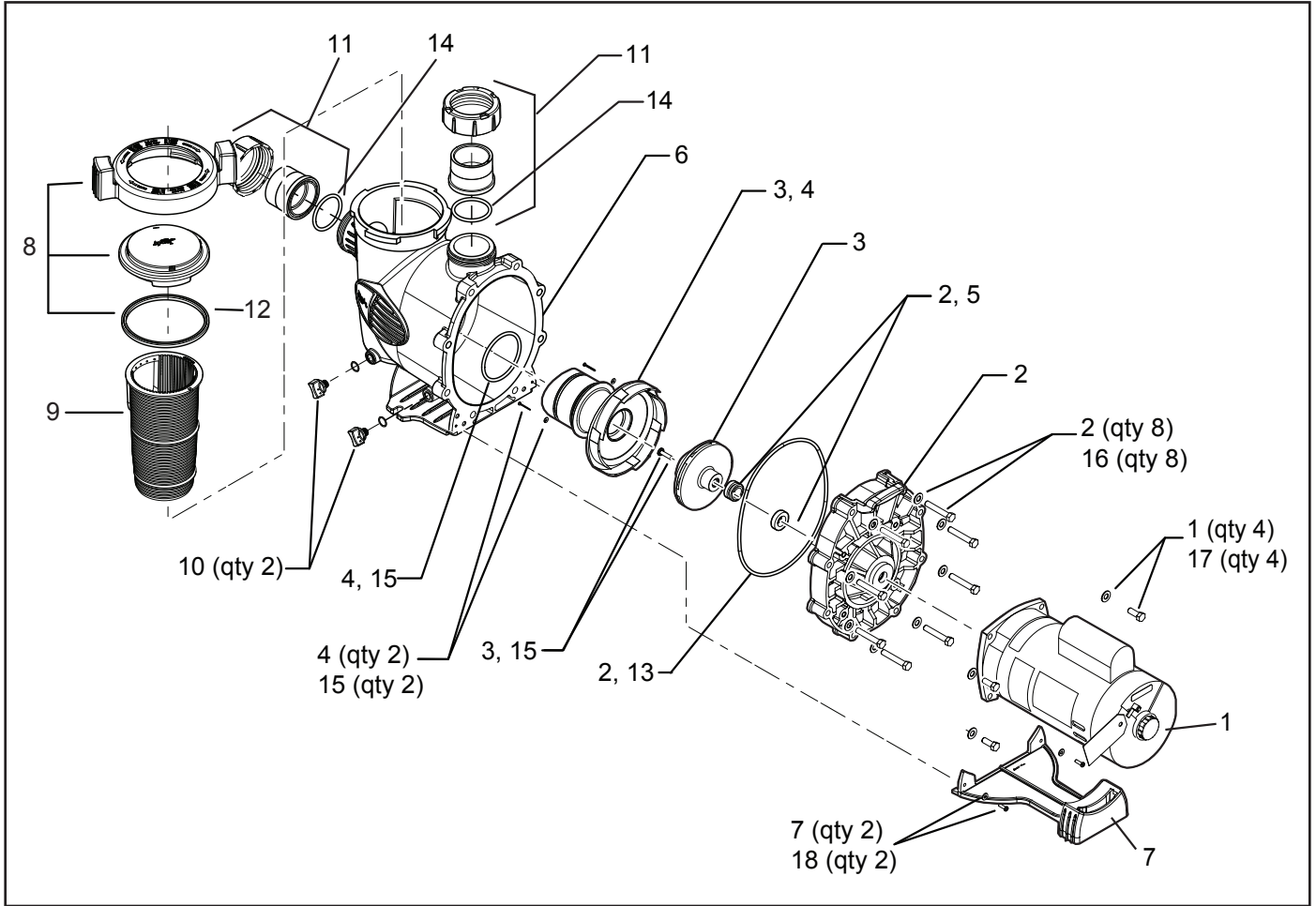
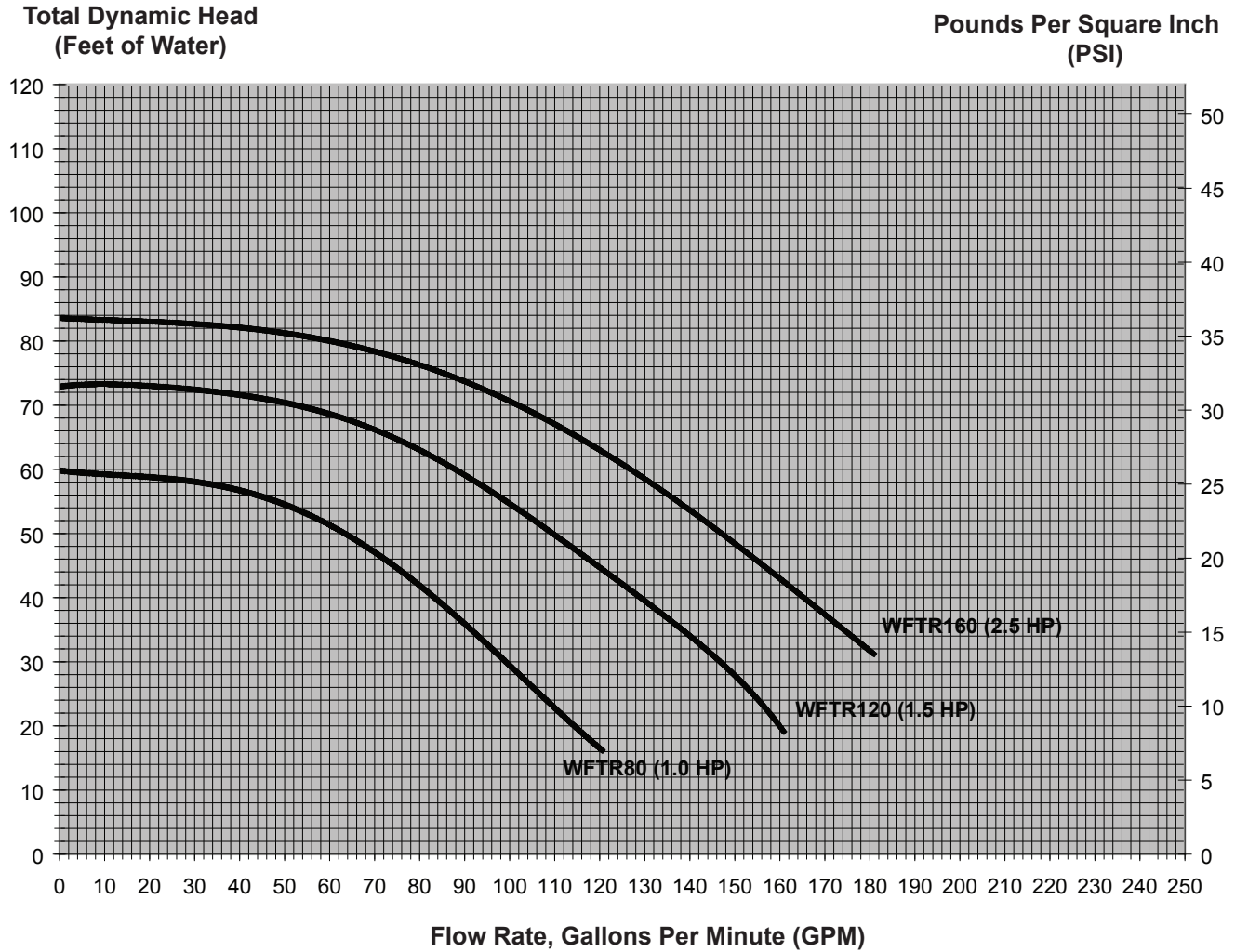

Figure 11. WFTR Exploded View

7.3 WFTR Pump Curves

Jandy Water Features Series High Head Pumps (WFTR)



7.4 Physical and Operational Specifications

7.4.1 WFTR Pump Specifications

Model No.	HP	Voltage	Amps	Pipe Size	Carton Weight	Overall Length 'A'
WFTR80	1.00	230/115	7.1/14.2	2-2½"	41.2	28⅞"
WFTR120	1.50	230/115	8.0/16	2-2½"	42.6	29¼"
WFTR160	2.50	230	11.5	2½-3"	48.6	30"

7.4.2 WFTR Pump Dimensions

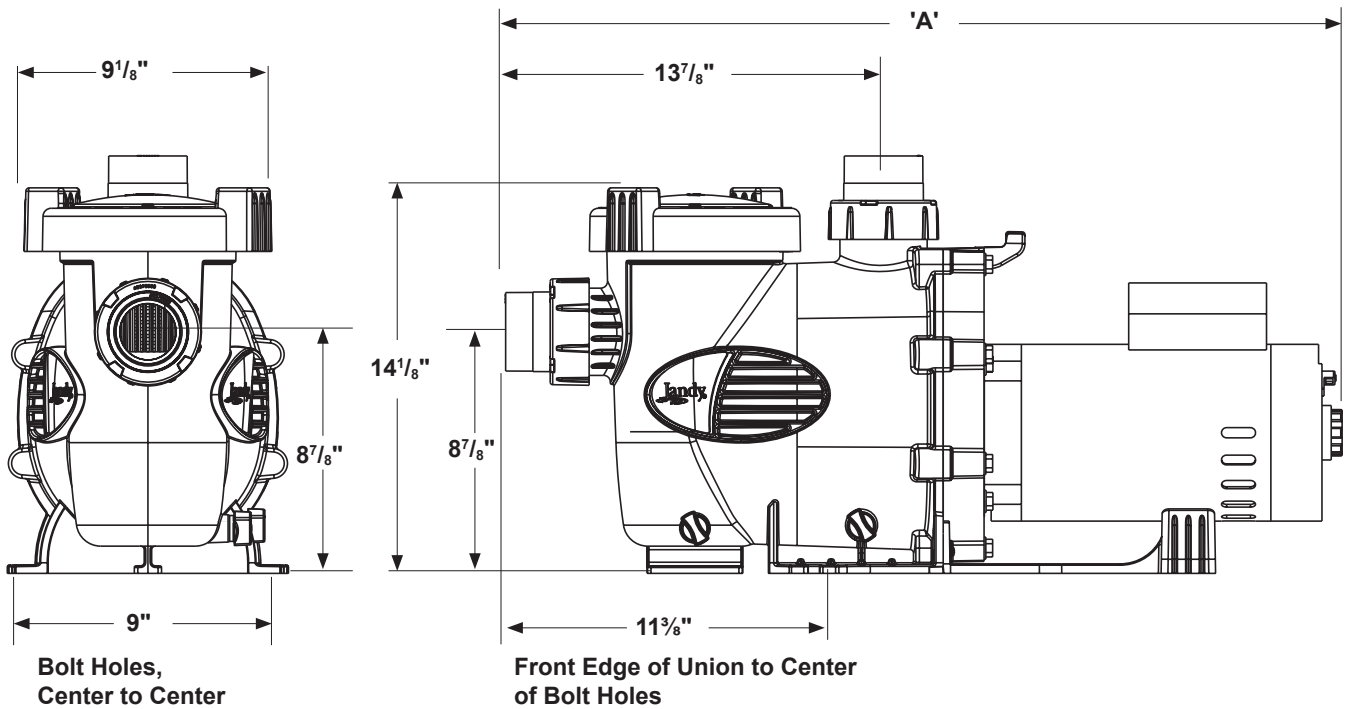

NOTE When installing the pump, leave a minimum of 2 feet of clearance above the pump for removal of strainer basket.

7.5 Replacement Motor Guide

WFTR Replacement Motor Guide

Pump Model	A.O Smith /Century	Emerson Motor Technologies
WFTR80	B853	EB853
WFTR120	B854	EB854
WFTR160	B840	EB840

NOTES



CONFORMS TO UL 1081
CERTIFIED TO CSA C22.2 NO 108

Zodiac Pool Systems, Inc.
2620 Commerce Way, Vista, CA 92081
1.800.822.7933 | www.ZodiacPoolSystems.com

ZODIAC® is a registered trademark of Zodiac International, S.A.S.U., used under license.
All trademarks referenced herein are the property of their respective owners.

©2012 Zodiac Pool Systems, Inc. H0320100 Rev B

